

HOLLOW CORE PLANK CONNECTION

DETAIL OF BEARING ON STEEL BEAM

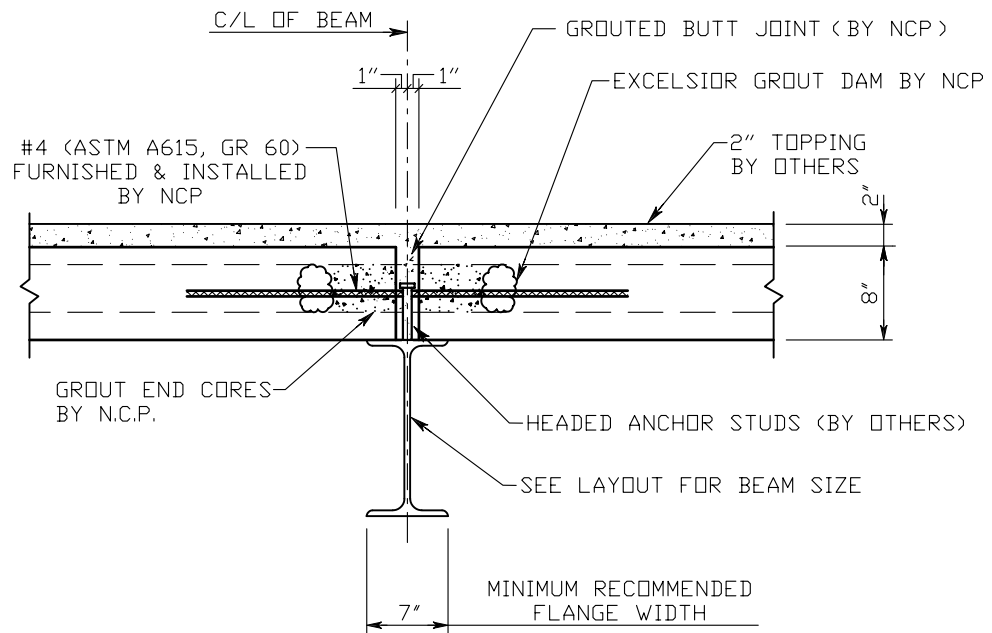

NOTES:

1. N.C.P. WILL PROVIDE A BROOMED FINISH IN ORDER TO CREATE A COMPOSITE TOPPING. C.I.P. TOPPING BY OTHERS IS TO BE 3,000 PSI. (NORMAL WEIGHT CONCRETE).
2. THE DESIGN OF CONNECTIONS FOR HOLLOW CORE PLANK TO OTHER BUILDING COMPONENTS IS THE RESPONSIBILITY OF THE ENGINEER OF RECORD, SINCE THEY ARE PART OF THE GLOBAL DESIGN OF THE STRUCTURE.
3. N.C.P. WILL PROVIDE A SMOOTH FINISH FOR INSTALLATION OF ROOFING MATERIALS BY OTHERS.
4. WELD PLATES ARE FOR BRACING THE COMPRESSION FLANGE OF THE STEEL BEAM AND FOR TRANSFERRING DIAPHRAGM FORCES. THEY ARE NOT TO HOLD THE PLANKS ON THE STEEL BEAMS. THE CONTRACT DRAWINGS SHALL INDICATE THE REQUIRED SPACING IN 4'-0" INCREMENTS.

2655 MOLLY PITCHER HIGHWAY SOUTH
BOX N, CHAMBERSBURG, PA 17201-0813
(717) 267-4505 FAX (717) 267-4518
ESTABLISHED 1923

NITTEHOUSE

CONCRETE PRODUCTS



CONCRETE