

HOLLOW CORE PLANK CONNECTION

DETAIL OF INTERIOR MASONRY WALL

2655 MOLLY PITCHER HIGHWAY SOUTH
BOX N, CHAMBERSBURG, PA 17201-0813
(717) 267-4505 FAX (717) 267-4518
ESTABLISHED 1923

NITTEHOUSE

PRODUCTS



CONCRETE

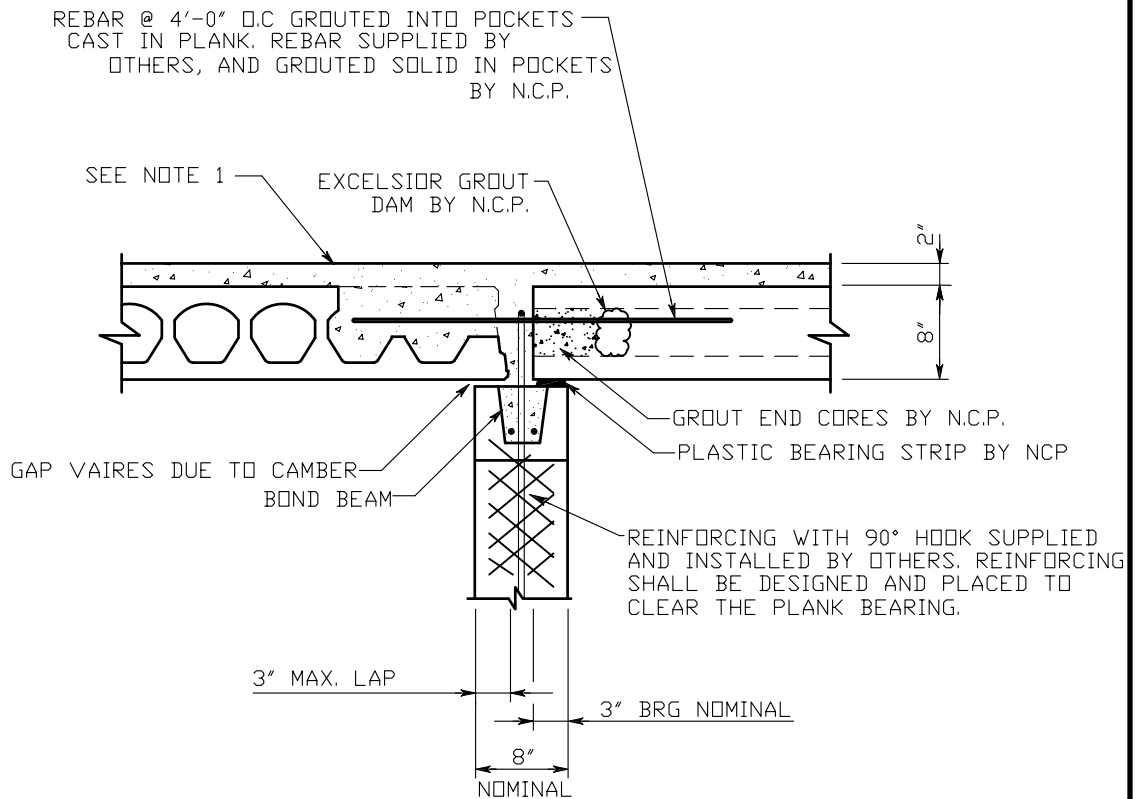
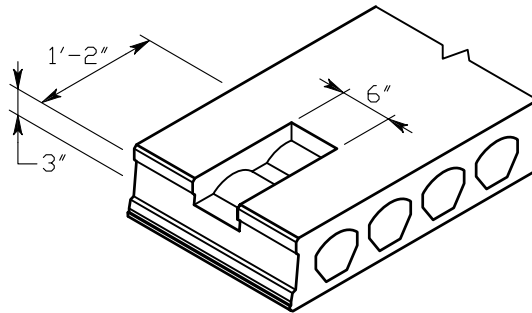

NOTES:

1. N.C.P. WILL PROVIDE A BROOMED FINISH IN ORDER TO CREATE A COMPOSITE TOPPING. C.I.P. TOPPING BY OTHERS IS TO BE 3,000 PSI. (NORMAL WEIGHT CONCRETE).
2. THE DESIGN OF CONNECTIONS FOR HOLLOW CORE PLANK TO OTHER BUILDING COMPONENTS IS THE RESPONSIBILITY OF THE ENGINEER OF RECORD, SINCE THEY ARE PART OF THE GLOBAL DESIGN OF THE STRUCTURE.